

MOONBLOOM pendant - sospensione

3000K **SE256 3B INT**
2700K **SE256 7B INT**

Matteo Ugolini design

2021

A - LAMP *corpo lampada* matt black aluminum - *alluminio nero opaco*

E - CEILING CUP *rosone* white plaster - *gesso bianco*

C - ELECTRICAL CABLE *cavo elettrico* black 2 meters - *2 metri nero*

ELECTRICAL SYSTEM *dispositivo elettrico* LED 24V, 16,8W*, 1821 Lm, CRI≥90

OPTIONAL *accessorio* power supply equipped - *alimentatore incluso*

PACKAGING *imballo* 104x91x17 cm

NET WEIGHT *peso netto* 14,5 KG

GROSS WEIGHT *peso lordo* 18,8 KG

IP RATE *grado protezione* IP20

CERTIFICATION *conformità* IEC 60598-1:2014 EN 60598-1:2015

EMISSION *emissione* bidirectional - *bidirezionale*

 direct - *diretta*

 filtered - *filtrata*

 indirect - *indiretta*

 none - *assente*

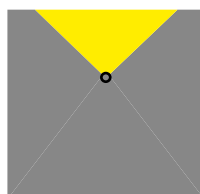

*(0-10V dimmable - dimmerabile 0-10V)

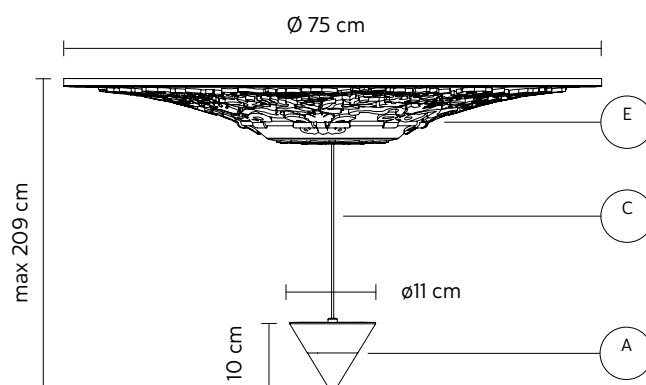

apparecchio fornito di sorgenti luminose di classe energetica E
lamp equipped with light sources energy class E

